

EX TF ... 100 L

Temperature sensor



Characteristics

- Full-protection due to encapsulation
- Aluminium cabinet
- Easy installation
- Protected supply cable (optionally)
- Laying sensor with special contact milling for heat conductor thermometry

Because of its increased test voltage for the insulation value, the interference resistance for measurements in outside facilities at long supply lines is ensured. The measured value is recorded by a resistor according to EN 60751 (Pt100), or DIN 43760 (Ni100) or IEC 751.

TYPE CODE

Connecting length 1,2 m is standard. Excess lengths more than 5 m must be requested separately, as for this purpose a special teflon coated shielded cable must be ordered. Delivery times must be requested when ordering.

Ex TF 1 **100 L** 2 3

1	Pt	Standard
	Ni	Nickel (as long as stocks last)
2	-	Standard
	s	with protective hose (The protective hose is a corrugated hose made of stainless steel and fixed with a special screw at the cabinet.)
3	-	Standard (1,2 m length)
	...	Value, e.g. 4 for 4 m length
	s	Special length \geq 5 m

Example: Device with Pt100, with protective hose and a standard length of 1,2m:

Ex TF Pt **100 L** S 2 3

TECHNICAL DATA

Nominal voltage	1,8 VdC
Nominal reading current	1 - 10 mA at 100 Ohm, \leq 1 mA at 1000 Ω
Series voltage U_s	24 V
Nominal resistance	100 Ω (Pt 100 or Ni 100)/ 1000 Ω (Pt 100)
Test voltage resistor	1100 V ~
Protection degree	IP65
Design cabinet (W x H x D)	74 X 22 x 22 mm
Connection lead	5-6 mm \varnothing , length 1,2 m (standard)
Mounting dimensions	63 x 14,5 mm
Measuring ranges	-40°C to +200°C
Temperature class	T6
Ambient temperature	-40°C to + 80°C
EC-type examination certificate	KEMA 03 ATEX 2425X
Ignition protection type (gas)	EEx d II C T6
Identification	 0344  II 2G EEx d II C T6

Table 1

	Temperature class			
	T6	T5	T4	T3
Max. admissible ambient temperature	+40°C	+55°C	+90°C	+155°C
Max. admissible sensor temperature	+40°C	+55°C	+90°C	+155°C

Field of application

The temperature sensor Ex TF...100 L is destined for the acquisition of temperature changes in potentially explosive atmospheres of zone 1 and higher. Its high test voltage guarantees operating safety also for long leads. The sensor can also be used as Ex-i-sensor, as no effective inductivities and outputs are measurable. The temperature sensor serves for temperature measurement of surfaces and ambient temperatures in protective cabinets. Depending on the used thermal element, different maximum measurable temperature ranges revealed.

WARMING UP OF THE SENSOR TIP

Dependig on the conditioning instrument, in the case of failure caused by the conditioning instrument, a maximum admissible power of 0,8 watt can be converted inside the sensing element. How large this output and the corresponding temperature rise really can be in the case of application, also depends on the type of installation. In the worst case at temperature rise of 35 K must be expected. For usual errors a temperature rise of \leq 12 K can be expected.

CONNECTION PLAN

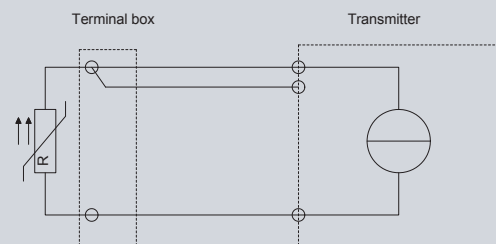

RESPONSE TIME

Temperature rise time of about 5°C/s in oil.

For an exact result the average value must be generated and the reaction time will become slower. It is barely possible to state an exact value at this, but roughly speaking would be about 100s for 150°C for oil.

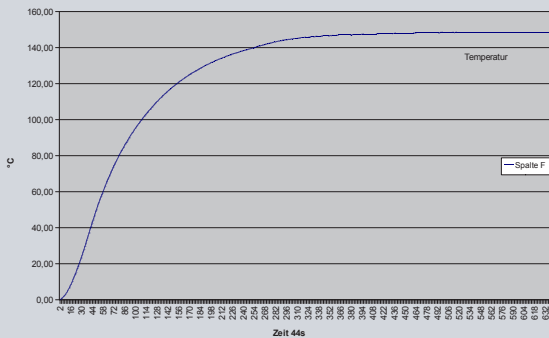

Generally:

The responding quality is decisively influenced by the heat transfer. In other media with a different heat conduction value, the values are accordingly different. Media with low thermal conductivity (e.g. air) lead to slow-blowing properties, therefore less °C/s. At media with higher thermal conductivity this leads to more °C/s. Here must be considered for the installation that the heat transfer is optimal to achieve high temperature rise rates, for example by the use of alu adhesive type for surface measurements.

ELECTRICAL ACCURACY

Exclusively sensors of class B are used:

Tolerances of the classes in °C: Class B: $dT = \pm (0,30 \text{ °C} + 0,005 \cdot T)$

NAMEPLATE

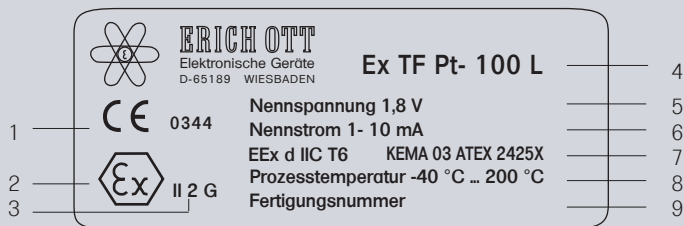

1-	Supervising agency	5-	Nominal voltage
2-	Ex- labelling	6-	Nominal current
3-	Ignition protection type	7-	Inspecting authority/EC-type examination certificate
4-	Type code	8-	Operating temperature
		9-	Production number

CABLES AND LEADS

For supply lines longer than 5 m the outer network must be earthed with PE at the feed point. The max. lead resistance of the supply line and its consistency depends on the presettings of the evaluation device. The inductivity of the device is negligible, the capacity of the sensor is ≤ 1000 pF. The supply line must basically be installed safely according to the standards of the EN 60079-14 and the regulations of technique. The lead end must be led into an appropriate terminal box. Attention should be paid to the fact that the screw joint through which the cable is led into the terminal box can seal up a lead with a diameter of 5 mm. the cold flow properties drop about approximately one decimal power per 10 K warming. A bending radius of $5 \times D$ (D = cable diameter) must be kept. The PTFE connection line must be installed non-spinning, without tensile load (≤ 1 kg) and with a bending radius of $10 \times D$ (≥ 60 mm) for permanent temperatures of more than 80°C.

MOUNTING METHOD

The fixture on pipings takes place by use of a metal tensioning strap combined with a tension lock above the terminal box. The clamping pressure must be chosen so high that the sensor can not be removed anymore from the installation site. For the installation on a mounting plate two holes are provided, with which the temperature sensor can be fastened on the mounting plate by using two M3 screws. Alternatively sheet-metal screws can be used

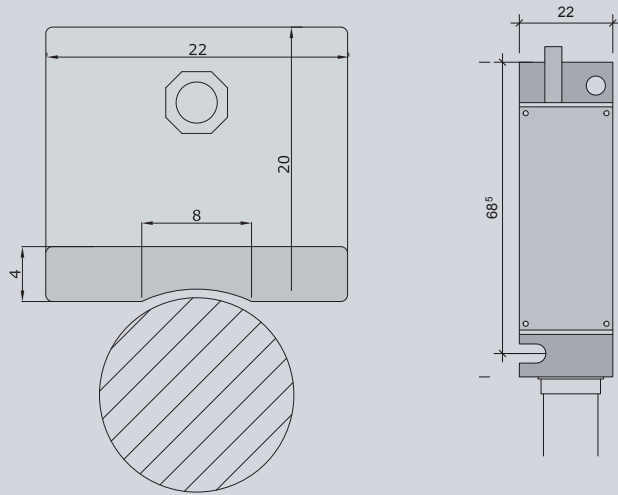

PROJECTING

For the accuracy of the temperature measurement it must be considered that both, effective heat capacity and the relation heat supply and heat dissipation can influence the measurement result. Very fast changes can accordingly be gathered with very small temperature sensors. Response graphs of the sensor can be sent when required.

As the sensor has a surface that bonds the surface of the object to be measured only slightly without special provisions, an intermediate value of ambient temperature and surface temperature of the object to be measured is metered. With appropriate arrangements such as insulation and suchlike the difference between those two temperatures can be kept as small as possible.

The dynamic error results from the ability of thermal energy storage of the sensor and the relation ability of thermal energy storage sensor to the object to be measured, whereas the mass of the object to be measured only has an influence on this relation in an immediate affinity of 2 bis 3 cm.

The observational error due to the connection line of the device, wheter 2-, 3- or 4-conductor circuit is, compared to the previous influence possibilities, generally negligible. For the uncertainty analysis the connection point in the terminal box can be regarded as the end of line fault and thus the complete circuit can be constructed as if the sensing element would be placed right there. The usual measuring error, conditioned by a test current of 10 mA amounts at 20°C less than 0,25 K.

Please take further data from the operating manual.
Download on www.erich-ott.de