

Ex TBK/ TRK KA

Capillary temperature controller and limiter



Features

- capillaries with VA-conduit
- modular design
- easy installation
- different cabinet sizes
- up to 4 devices in one cabinet
- simple optical alignment
- good legibility of the temperatures
- versions for different temperature ranges

Temperature changes are recorded by the sensor and directly transmitted through the capillaries and membranes to the precision snap-action switch. The switching temperature can, after removing the cabinet cover, be adjusted by a wheel with a temperature range from 0°C continuously. Temperature setting and limiter resetting can also be carried out under tension (terminal block covered). The representation of the contact in the wiring diagram assumes that the sensor temperature is more than 5 % or rather 5°K lower than the temperature set on the setpoint tuner. The devices each have only one set point and a transfer contact (changer). The capillary controller - limiter is suitable for temperatures up to 300°C and 16 A/ 400 V.

The maximum operating voltage is 400 V. The load is switched on single-pole microswitch with potential free contacts, in which the max. switching current is 16 A. The switches are housed together with spring terminals for easy wiring in an explosion - cabinet. The sensors consist of liquid-filled flask with 1 to 3 m long capillary tube of stainless steel. The thermostat is delivered with Ex-approved cable glands and blanking plugs, in which this cable management opens up multiple connections, such as: power supply loop to save connection boxes and the possibility of using M25 and M32 glands for direct heater circuit conduct and the alarm output. The temperature controller or the thermostat is designed for the use in industrial plants and it is used for temperature measurement of surfaces, air temperatures or in

protective tubes for general two-point control. In particular it is intended for heating system and protective cabinet heaters within a hazardous area zone 1 or higher. The flameproof switch element is mounted in a case of protection „increased safety“. The enclosure material is polyester. The switching element of the limiter has a manual reset mechanism.

TYPE CODE

The order of the abbreviations is the order in which the base units are installed. A letter is always followed by the associated two numbers. The first module determines the type designation. R and B are thus given for the first module.

Ex T

1

 K

2

3

4

5

6

 KA

1	B	Limiter
	R	Controller
2	Temperature setting range	
	5	0 to +50°C
	1	0 to 100°C
	3	0 to 300°C
3	Capillary length	
	1	1 m
	3	3 m
	5	5 m
4	Combination unit (e.g. TBK/TRK)	
5*	M	M32 gland
	R	M32 reduction to M25
	B	blanking plug
6	-	Screw terminals (standard)
	Z	Cage clamp

* The number of glands depends on the size of the cabinet (see table 2, chapter. 7.0). M25 and M32 glands can be freely combined. The only exception is the smallest cabinet (160 x 75 x 75), which is supplied with only one M25 gland.

TECHNICAL DATA

Measuring ranges	0-50°C, 0-100°C and 0-300°C
Capillary length	1 m, 3 m, 5 m
Contact Switching capacity AC voltage	max. 4000 VA min. 10 V, 0,1 A
Nominal current	16 A ~
Nominal voltage	400 V ~
Type of protection	IP65
Dimensions (B x H x T): Polyester Mounting dimensions	160 x 75 x 75 mm 148 x 45 mm
Ambient temperature	- 40°C - +60°C**
**Continuous service temperature cable	≤ 90°C
Cable gland	M 25 Ms-ni (-40°C - 100°C) terminal box 160x75 M 32 plastic (-40°C - 70°C) terminal box 160x160; 160x260; 160x360 PG 9 metal (-40°C - 100°C) module
Extension lead	M25 Ms-ni round cable diameter 11,5 mm - 15,5 mm M32 plastic round cable diameter 12 mm - 21 mm PG 9 metal included in scope of delivery (module)
EU-type examination certificate	PTZ 16 ATEX 0019 (Single- and combination unit)
Type of ignition protection (gas)	II 2 G Ex db eb mb II C T6 Gb
Type of ignition protection (dust)	II 2 D Ex tb IIIC T100°C Db
Labelling	0344 II 2 G Ex db eb mb II C T6 Gb II 2 D Ex tb IIIC T100°C Db

COMBINATION DEVICES

Different users need several independent temperature limiters, controllers or switches for an object. Therefore we offer combinations of base units in a junction box or it is possible to place a base unit in a larger terminal box. At the same time it is then necessary to provide the basic unit as a spare part. There are three terminal boxes for 1 to 4 base units, equipped with terminals 2,5 (4) mm² and glands M32, M25.

Number of modules	1	1	2	3	4
Type designation	T...K	T...K	T...K/ T...K	T...K/ T...K/ T...K	T...K/ T...K/ T...K/ T...K
Cabinet size	160x75x 75	160x160x 90	260x160x 90	360x160x 90	360x160x 90
Mounting dimensions	148x45	140x110	240x110	340x110	340x110
Number of glands	M25	2xM32	3xM32	4xM32	4xM32

LIMITER ACTION

After opening the cover, the desired temperatures can be adjusted at the thermostates.

They operate on the principle of liquid expansion. If the temperature changes in the fluid-filled sensor systems (consisting of probe, capillary and membranes), the volume changes. The thereby resulting movement of the membranes actuates the micro switch via lever.

When the set temperature is exceeded, the temperature controller switches from clamp 5 to clamp 6 and the temperature limiter switches from clamp 2 to clamp 3.

The safety thermostat can be turned on again by pressing the limiter release after the temperature drops.

After setting the desired temperature, the cabinet cover, gasket included (undamaged), must be mounted again, as this is the only way to guarantee protection IP 65 and the explosion protection.

LIMITER RESETTING

The safety temperature limiters are equipped with a lock-out. An automatic resetting is not possible.

Each safety temperature limiter needs to be reset over manual reset button after correcting the failure.

The reset can only be done after reaching the normal operating conditions. At too high temperature the reset button is mechanically blocked. The release of the reset button is only possible after the fall below the nominal available.

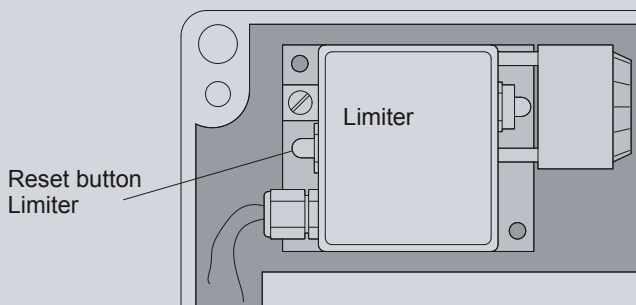

ASSEMBLY

To mount the device on a mounting plate, four holes are provided on the housing of the temperature controller and limiter to attach the device to the mounting plate using two M4 (M5) screws DIN84. The supply must be laid safely according to the guidelines of the cable installation. The seal inserts for the cable entry must be chosen according to the pipe diameter.

For the attachment no metal bands may be used, as these could deform the sensor during tightening. For this reason the use of fiberglass tape is recommended.

The capillary tube should be possibly laid protected, the minimum bending radius of 15 mm is required in any case. Cutting or bending leads to permanent failure of the device. A repeated bending of the capillary tube, must be omitted, as this can lead to hair-tearing.

DEVICE STRUCTURE

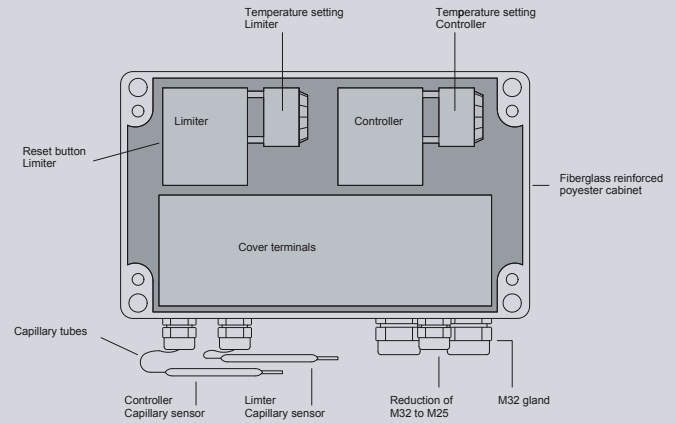

NAMEPLATE

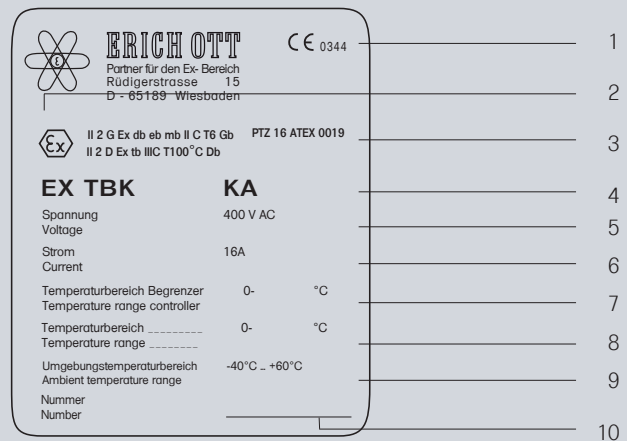

1- Supervising agency	6- Nominal current
2- Ex- Marking	7- Adjustable temperature range controller
3- Testing agency/EU-type examination certificate	8- Adjustable temperature range limiter
4- Type designation	9- Admissible ambient temperature
5- Nominal voltage	10- Serial number

CONNECTION EXAMPLES

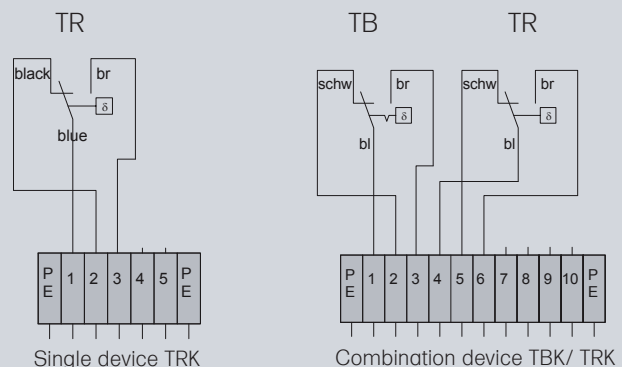

For further information please refer to the instruction manual. Download on www.erich-ott.de