

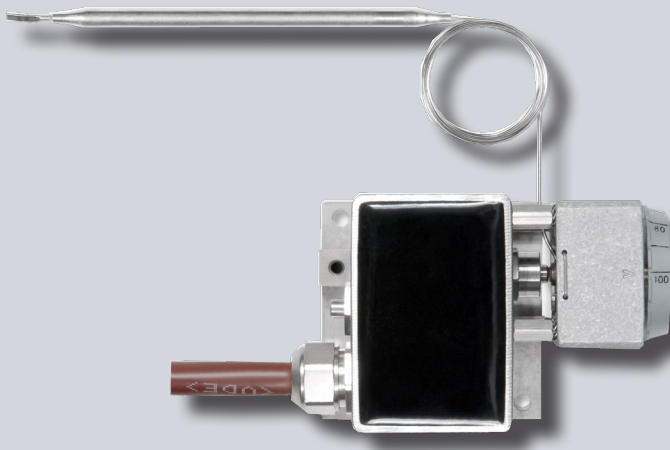

Ex TBK/ TRK KA/ U

Capillary temperature control and limiter module



Identification	 II 2 G Ex db mb II C T6 Gb
EU-type examination certificate	PTZ 16 ATEX 0020 X
Ambient temperature range	-40°C - +60°C
Control range	0°C - 50°C 0°C - 100°C 0°C - 300°C
Rated current max.	16 A
Rated voltage max.	400 V~
Switching capacity	4000 VA
Type of protection	IP65

Temperature limiter module

The capillary temperature modules are available as regulator or limiter module. They are used for regulating or limiting trace heating in hazardous areas of zone 1 or higher.

Equipment and protective systems intended for use in hazardous areas according to directive 2014/34/EU.

Temperature limiter module	Ex TBK ... / .. KA/U
Temperature control module	Ex TRK ... / .. KA/U

TABLE OF CONTENT

1.0	Description	2
2.0	Notes on installation and operation	2
2.1	Installation.....	2
3.0	Technical data	2
4.0	Limiter action	Back page
5.0	Serial number	Back page
5.1	Ordering indications	Back page
5.2	Nameplate	Back page
6.0	Connection plan	Back page



Warning

The installation, configuration and commissioning may only be carried out by appropriately trained personal. On-site installation and safety regulations must be observed..



Reservation

Technical alteration without prior notice. Changes, mistakes and misprints are no reason for a claim for damage. For security components and systems the relevant standards and regulations must be observed and the corresponding operating and assembly instructions.



Installation notes

For the installation / operation the relevant standards and the applicable regulations for installation as well as the generally recognized regulations of industry and these instructions shall prevail. The devices should not be thrown or fall. If a damage to the device is detected, the device must be sent back for examination. If during commissioning difficulties arise however, we ask you not to carry out any unauthorized manipulations of the device, otherwise the warranty and the validity of the EU-type examination certificate void. Please contact us. In case of service the device must be returned to us.

Special conditions

1. The temperature limiter and the temperature controller is only designed for the incorporation into appropriate cabinets of protection type „increased safety“ with separate EU-type examination certificate.
2. The determination of the temperature class and the maximum ambient temperature range is made by the producer by thermal routine test in the light of self-heating in the used cabinet. The maximum permissible ambient temperature range stated on the front page applies only to the temperature controller or the temperature limiter itself. According to the self-heating which results during the fitting into a cabinet, the lower permissible maximum external temperature must be indicated and specified on the label.

3. The temperature limiter or the temperature controller may also be used as part of a control with separate EC-type examination certificate. Notwithstanding the „special condition“ No. 3, the identification of the temperature class and the maximum ambient temperature range then follows by the manufacturer of the control as defined in the corresponding EU-type examination certificate. The specified maximum permissible ambient temperature range should not be higher or lower.



Repair

The repair can only be carried out in the plant. The drive of the capillaries is repairable. A repair of the switching element however is not possible. Changes, that alter the design of the device will void the validity of the certificate and any warranty claims.

Read these instructions before putting the unit into operation. Keep the manual at a place accessible for all users at any time. Please help us to improve this manual. We are grateful for your suggestions.

Contact us for technical queries!
 TELEPHONE: +49 (0)611 94587267
 TELEFAX: +49 (0)611 94586124
 E-Mail: info@erich-ott.de

1.0 DESCRIPTION

Features

Modules for Ex-terminal boxes
Replaceable
Can be used as replacement
Available as regulator or limiter
Easy installation
Good readability of the setpoint temperatures
Versions for different temperature ranges
Proven reliability
Limiter current 16 A



The basic units are designed for retrofitting and for mounting in a control system with separate EC-type examination certificate. The temperature controller or the temperature limiter is designed for the use in industrial plants and used for temperature measurement of surfaces. In particular it is intended for heat tracing and heating within a protective cabinet Ex-area of zone 1 or higher.

The pressure-proof encapsulated switching element of the limiter has a manual reset mechanism.

Temperature changes are recorded by the sensor and directly transmitted through the capillaries and membranes to the precision snapaction switch. The switching temperature can be continuously adjusted by a hand wheel with temperature scale from 0°C. Temperature setting and limiter resetting can also be carried out under tension. The representation of the contact in the wiring diagram assumes that the sensor temperature is more than 5K lower than the temperature set on the setpoint turer

3.0 TECHNICAL DATA



Measuring ranges	0-50°C, 0-100°C and 0-300°C
Capillary lengths	1 m, 3 m, 5 m
Switching voltage U_{Schalt}	$12\text{ V} \leq U_{Schalt} \leq 400\text{ VA}$
Switching power I_{Schalt}	$0,01\text{ A} \leq I_{Schalt} \leq 16\text{ A}$
Switching capacity P_{Schalt}	$0,12\text{ W} \leq P_{Schalt} \leq 4000\text{ W}$
AC	$U_N \leq 400\text{ V} \sim I_N \leq 16\text{ A}$
DC	$U_N \leq 250\text{ V}, I_N \leq 0,25\text{ A}$
Type of protection	IP65
Dimensions cabinet (W x H x D): Mounting dimensions	91 x 60 x mm 50 x 50 mm
Ambient temperature range exclusive capillaries	- 40°C - +60°C (Continuous service temperature cable $\leq 90^\circ\text{C}$)
Cable gland	PG 9 Metal screw
EU-type examination certificate	PTZ 16 ATEX 0020 X
Type of ignition protection (gas)	II 2 G Ex db mb IIC T6 Gb or rather T5 or rather T4
Identification	 0344  II 2 G Ex db mb IIC T6 Gb

Table 1

Setting ranges	0..50°C	0..100°C	0..300°C
Cutoff accuracy*	$\pm 1\text{ K}$	$\pm 1,5\text{ K}$	$\pm 4,5\text{ K}$
Switching difference	$\pm 1,5\text{ K}$	$\pm 3\text{ K}$	$\pm 9\text{ K}$
max. sensor temperature	70°C	120°C	320°C
Sensor dimensions	6x250 mm	6x135 mm	4x175 mm
Capillaries (V4A)	1 / 3 / 5 m	1 / 3 / 5 m	1 / 3 / 5 m

*Condition at delivery. Depending on the ambient temperature this value can double.

2.0 NOTES ON INSTALLATION AND OPERATION

The capillaries may not be squashed or kinked. This applies to storage and transport. The minimum bending radius of 15 mm must be observed. The sensor itself may not be deformed in any way. The smallest deformation means maladjustment and thus a deviation from the set point of the temperature set on the inner adjuster. The measured temperature corresponds to the mean temperature of the capillary. The temperature of the capillary drive and the switching element have very little influence on the switching behavior. The sensors may be heated max. 20% over the measuring range, without any misalignment of the switching point. All designs must be tested before use and after installation at temperatures above 0°C for their ability to function. The contact of the switching element is a power contact. Too small switching power (lower than 10 mA, 12 V) can lead to high contact transitions and thus to functional incapacity. This error can be corrected by switching a lamp of 50 watts 230 volts. After that the unit can be used for small electrical ratings higher than 10 mA and 12 V again. The interconnection of individual approved components to one heating corresponds to a a new unit, in which the temperature behavior must as a rule be re-evaluated at proper installation. This is not covered by the existing EC-type examination certificate.

The sensor is fixed on the pipe using a tension band or tape. It is important to avoid exerting pressure on the sensor system. It must be ensured, that even during operation no pressure will be exerted on the sensor system.

The specific conditions of the EC-type examination certificate must be respected.

2.1 INSTALLATION

There are two holes with a diameter of $\varnothing 4,3\text{ mm}$ provided, with which the unit can be attached to the backing plate of the ex-cabinet using two M4 (M5) bolts. Spacing for the attachment see drawing chapter. 6.0. The supply line must be laid safely according to the guidelines of the line installation. Preferably used should be rust resistant screws of strength class 8.8 or higher. The screws must be secured against loosening.

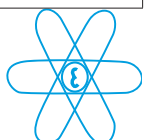



4.0 LIMITER ACTION

After opening the cabinet cover, the wanted temperatures can be set at the thermostates. They work on the principle of liquid expansion. If the temperature changes in the liquid filled sensor systems (consisting of sensor, capillary pipe and membranes), the volume changes. The resulting movement of the membranes actuates the micro switch via lever. The safety temperature limiter can only be switched on again by using the limiter unlocking after the temperature has dropped. The temperature of the setting scale refers to the temperature, which is applied in the front, compressed part of the sensor. The temperature of the remaining elements has negligible influence on the switching behaviour.

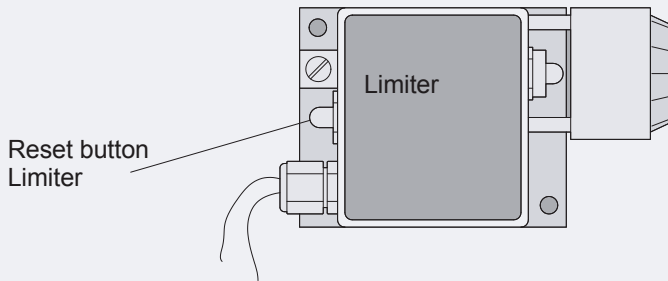

5.0 SERIAL NUMBER

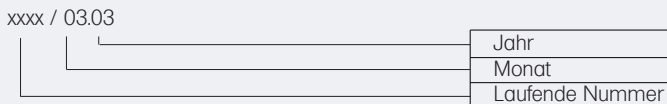

5.1 TYPE KEY

For Limiter **Ex T**

1

K

2

 /

3

KA/U

1	B	Limiter
	R	Controller
2	Temperature setting range	
	5	0 to +50°C
	1	0 to +100°C
	3	0 to +300°C
3	Capillary length	
	1	1 m
	3	3 m
	5	5 m

Example:
Limiter with a temperature setting range of 0 - 50 °C and a capillary length of 1 m:

T

B

K

5

1

KA/U

5.2 NAMEPLATE

	ERICH OTT Partner für den Ex-Bereich Rüdigerstrasse 15 D - 65189 Wiesbaden	CE 0344	1
EX TRK		KA U	2
Nennspannung	400 V AC		3
Nennstrom	16A		4
Temperaturbereich	0- °C		5
Umgebungstemp.	-40°C ... +60°C		6
PTZ 16 ATEX 0020 X			7
Fertigungs Nr.			8
	Ex db mb II C T6.Gb		9

1-	Supervising agency	5-	Setting temperature range
2-	Type designation	6-	Permissible ambient temperature
3-	Rated voltage	7-	Testing office/ EU-type examination certificate
4-	Rated current	8-	Serial number
		9-	Ex-Identification/Type of ignition protection

6.0 CONNECTION PLAN

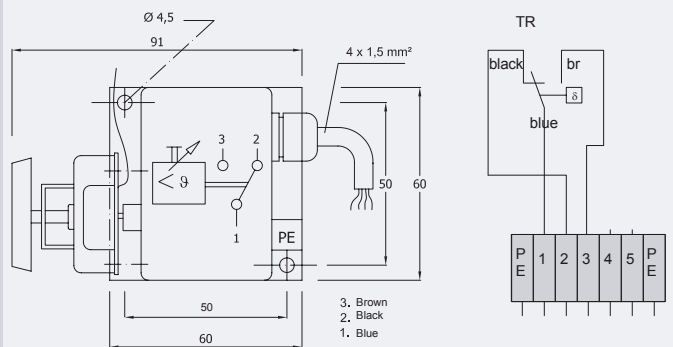

TRK KA/U



Erich Ott GmbH & Co. KG
Partner für den Ex-Bereich

D- 65189 Wiesbaden
Rüdigerstrasse 15
Telefon +49 (0) 611 - 94587267
Telefax +49 (0) 611 - 94586124

mail info@erich-ott.de
web www.erich-ott.de