

SIPT

Power controller



Characteristics

- Field device for zone 1
- Immediate overview of desired value and limiter
- Signal lamp
- 2 sensor inputs
- Parameterization easily understandable
- Easy installation
- Separate fault signal relay for both controller and limiter
- Sensor cable monitoring of all 3 conductors

The ideal solution for trace heatings SIPT provides temperature control, -limitation and power control in one device. The equipment includes temperature limiter and indicator lamp. SIPT is ATEX certified and approved for the use in the Ex-area in zone 1. Cost-effective in maintenance and repair because of modular design. Designs with digital display and external actuation possible on request. All functional units are integrated in an antistatic standardised housing. The connecting leads up to 6 mm² are contacted with cage spring release terminals. The measuring circuit is not intrinsically safe.

Sensor

Sensors, which are used in potentially explosive areas, must meet the requirements of the guideline 94/9/EG for the respective zone. In this context we can offer the temperature sensors from our product range. (See sensors). The load current is interrupted, no matter which of the 3 cables for the Pt 100 is disconnected. Furthermore an interruption occurs at conductor fault. The 3-wire circuit of the measuring input is as standard reduced to a 2-wire switch at the terminal strip by use of a bridge for short sensor lines and can be changed to a 3-wire switch.

Function

The controller is designed as two-level controller and measures the temperature via Pt 100. The limiter works as stand-alone system and measures the temperature at the hot spot with its own Pt 100. If the temperature exceeds the threshold value, the limiter interrupts the heating permanently and a signal follows.

Detailed information about the used limiters can be found in the operating manual of the temperature limiter Ex B Pt100.

With the min.-monitoring a decrease of the temperature under a pre-determined threshold value can be recorded in time, to possibly resolve a disturbance before the occurrence of a damage. The temperature switching point is adjusted at the min. scale.

After a failure of the supply voltage all previous functions switch on again automatically when the power returns, if the limiter circuit was

not blocked by an excess temperature release. This spares the maintenance personnel from reconnecting (limiter resetting) each single controller by hand.

The setpoint adjuster limiter is sealable.

The device is suited for small load resistances.

The fault signal relay responds to each of the following errors (drop in neutral position).

Limiter	Controller
Min.-temperature underflow	Min.-temperature underflow** (only design with digital display)
Triggered limiter	Sensor short circuit
Sensor short circuit	Seonsor break
Sensor break	Measuring cable interruption*
Measuring cable interruption*	Measuring line fault*
Measuring line fault*	
Power failure	

* no matter, which of the 3 measuring lines is affected

** Common expression, strictly speaking a voltage regulator that keeps the adjusted effective voltage at one level.

TYPE CODE

SIPT



1
2
3
4
5

 AT

1	P	Sensor Pt100
	T	Thermal element
2	1	Measuring range for controller 100°C (Standard)
	2	Measuring range for controller 200°C
	3	Measuring range for controller 300°C
	4	Measuring range for controller 400°C
3	2	Measuring range for limiter 200°C (Standard)
	3	Measuring range for limiter 300°C
	4	Measuring range for limiter 400°C
4	-	Standard
	E	Only voltage regulator + Temperature controller*
5	-	Standard
	Ae	With external adjuster

* the fault signal lamp is not applicable for these designs

GENERAL TECHNICAL DATA

Nominal voltage	230V ±10% 50-60 Hz
Protection degree	Min. IP65 / DIN 60529
Admissible ambient temperature range	-30°C bis +40°C
Dimensions	Breite 260 mm Höhe 160 mm Tiefe 90 mm
Electrical connection	Klemmen für 4 mm ²
Mounting	Raster 240 mm x 110 mm für 4 x M4 Schrauben
EU-type examination certificate	ISSeP08ATEX023X
IEC Standards	EN 60079-0, EN 60079-1, EN 60079-7, EN 60079-18
Type of ignition protection	Ex e mb d IIC T4
Identification	 0344  II 2G Ex e mb d IIC T4

The complete Atex approval documentation can also be found as pdf-document on www.erich-ott.de.

Rated current	60 mA (120 mA) internal consumption
Insulation voltage*	
Inputs-network	2,5 kV~
Network-cabinet	2,5 kV~
Input-cabinet	2,5 kV~ (* inputs short-circuited)
Sensor	Pt 100 (Ni 100)
Measuring current	6 mA, 3-wire circuit
Measuring circuit monitoring	all 3 lines
Setting range temperature	0 ... 100/ 200/ 300/ 400°C
Setting range voltage	20 ... 230 V

TECHNICAL DATA SEMICONDUCTOR CIRCUIT

Rated current	16 A (45 A)*
Power dissipation	~1 x Ib +5 (in Watt) (Ib = operating current of the heating)
Resistance region of the heating cables	3 - 500 Ω without limiter **

* Rated current of the semiconductor

TECHNICAL DATA LIMITER

Sensor input	Temperature sensor Pt100, Ni100
Measuring circuit	6 mA, 3-wire circuit
Measuring circuit	all 3 lines
Line break	≥ 200 Ω for Pt100 (or 20 % above the measured value range)
Short-circuit	≥ 50 Ω (or 20 % above the measured value range)
Setting range/ Scale	0 ... 200/ 300/ 400°C
Limit adjuster	Precision potentiometer; rotation angle 300°
Switching point accuracy	≤ 1,5 %
Switching point hysteresis	≤ 3 K (for 200°C scale)
Limiter relay	1 potential-free changeover contact 250/ 440 V ; 16 A (25 A)*; cos φ 0,7 ; 4000 VA (see load diagram)
Resetting	Key switch in front panel of the module
Upstreaming fuse	≤ 16 A
Requirement category	AK4

* max. inrush current impulse (4sec), no continuous operation

TECHNICAL DATA MIN. MONITORING

Setting ranges (Scales)	0 ... 100/ 200/ 300/ 400°C
Setpoint adjustment	Precision poti; rotation angle 300°
Switching point accuracy	≤ 1,5 %
Switching point hysteresis	≤ 2 K (for 100°C scale)
Fault signal	By fault signal relay d2
1 potential-free make contact	250 V; 5 A cos φ 0,7; 1250 VA; 30 V=; 5 A; 150 W

SENSOR

Pt-100 sensors are part of the EMV examination. Certified and used can be :

Ex TF-Pt100 L and Ex TF-Pt100 Ks

(Other designs can be tested by us.)

CABLES AND LEADS

- Supply lines to the switch cabinet or rather distribution board must be designed in 3-wire or rather 5-wire technique.
- Only heating cables with exterior shielding are admissible. B.
- Measuring- and control line: There must always be two adjacent conductors connected inside the cable for one signal.

TYPE PLATE

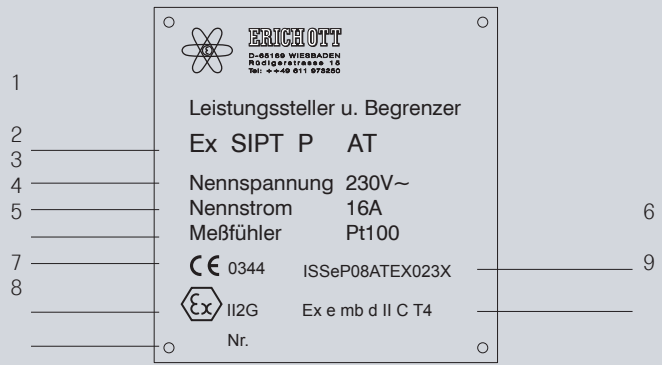

1-	Type designation	5-	Supervising agency
2-	Nominal voltage	6-	Inspection authority/ EC-type examination certificate
3-	Rated current	7-	EU-identification
4-	Sensor	8-	Production number
		9-	Type of ignition protection

DIMENSIONS

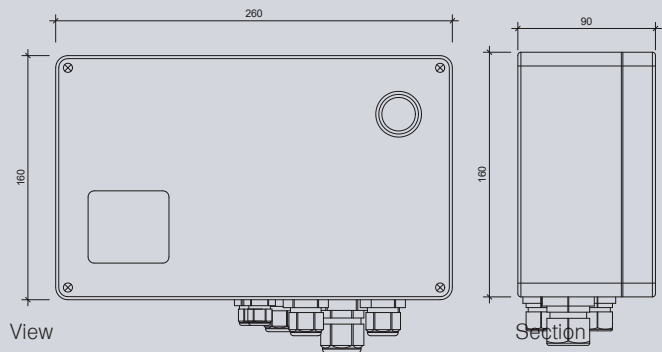

CIRCUIT DIAGRAM

