

SRS ... / 8 - 16

Voltage controller



Characteristics

- Constant output voltage
- Analog input 4-20 mA
- Easy installation
- Setpoint switchable

The voltage controller is suitable for ohmic and inductive loads similarly.

With the help of the voltage controller e.g. the effective current is adjusted for the heating. It is recommended to adjust the current with the help of an amperemeter that indicates the effective value.

- Constant output voltage by regulating to the adjusted setpoint
- On- and off switching operation via optocoupler (VDE 700-730).
- No semiconductor fuse necessary.

When applying a voltage to the terminals 1+2, the voltage controller switches off.

TYPE CODE



1	230 V ~ / 400 V ~	Nominal voltage
2	8-16	Input optocoupler
	xx	Special construction possible on customer request
3	-	
	AN	With analog input

Example: Nominal voltage 230V, 8-16 A nominal current, with analog input

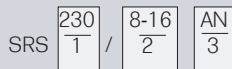

TYPE PLATE

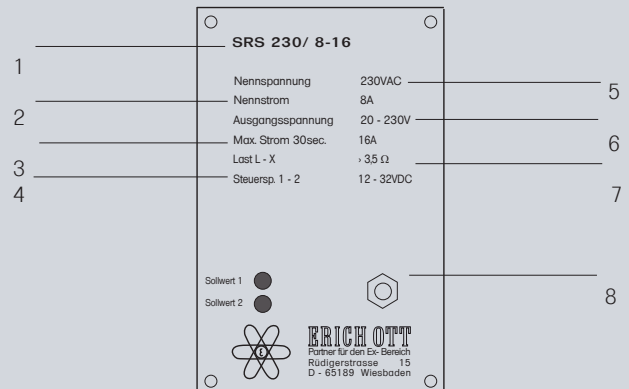

1- Type designation	5- Nominal voltage
2- Nominal current	6- Output voltage
3- Max. current 30sec	7- Load L - X
4- Control voltage 1 - 2	8- Toggle switch for setpoint 1 or 2

MOUNTING DIMENSIONS

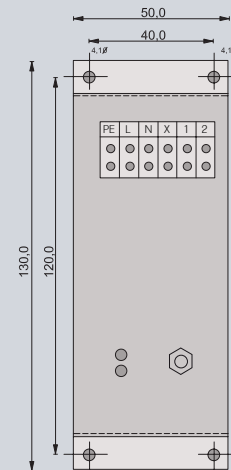

TECHNICAL DATA

Nominal voltage	230 V (400 V~)	
Nominal current max.	8 A (temporary 16 A)	
Setting ranges voltage	20 - 230 V (40 - 400 V) depending on design	
Max. current load of the semiconductor	0,2 s; 200 - 500 A	
Input optocoupler	12 - 32 V, Rj = 5 K disconnection according to VDE 0700	
Temperature range	0 - 55 C	
Alternative	without setpoint commutator	
Analog input	4 - 20 mA	as specified (0 - 190V)*
		230 V

* if 4 mA does not correspond to 0 v, a corresponding switch must be provided for the heating.

CIRCUIT DIAGRAM

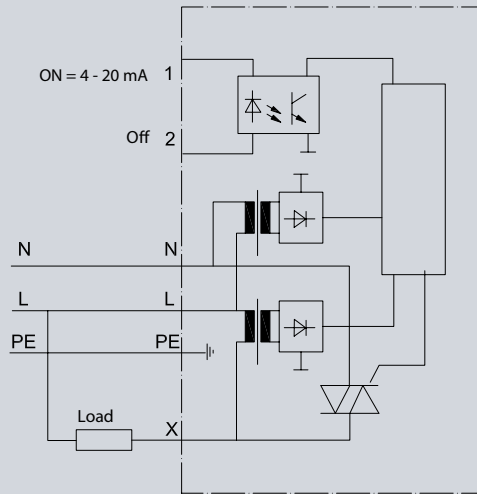

Please take further information from the operating instructions.
Download on www.erich-ott.de